



JAN DES BOUVRIE



Maretti Lighting  
Bolderweg 7

1332 AX Almere  
the Netherlands

T +31 (0) 36 532 66 12  
F +31 (0) 36 532 17 35

E info@maretti.com  
W www.maretti.com

Modern and white - the trademark of Jan des Bouvrie. Cubist styled furniture and mainly white designs; the art of living. In a very refined way and with subtle colours Maretti knows how to reinforce Jan des Bouvries vision. In particular colour changing LED lighting has his preference and is applied by Maretti in many of his interior designs.

© Copyright Maretti Projectverlichting.

Our IM was made with the greatest of care. Nevertheless, the colours displayed in the IM may differ slightly from the real colours because of the printing process. Colour, size and range are subject to change. Nothing from this IM may be copied, reproduced and/or published by print, photocopy or in any other way without Maretti Lighting's written permission. All product and design copyrights belong to Maretti Lighting.

**GUARANTEE TERMS AND CONDITIONS**

The other party should inspect the delivered items immediately upon receipt with regard to its soundness. Entitlements to repair or replacement only exist if the other party

- In the case of visible defects, informs MPV of them immediately.
- In the case of defects that are not visible, informs MPV in writing of the defects, within 2 working days after the day the defects were found, or in all reason could have been found and furthermore demonstrates that the MPV instructions for use, maintenance and operation were followed, whilst the defects are not the consequence of normal wear and tear, misuse, negligence, accident, exceeding the limits prescribed by the MPV or by the legal safety regulations, or, in the case of a repair or change without MPV's consent or the consent of its recognised repairer, there will be no entitlement to repairs or replacement.

The parts that have to be replaced must be made available free of charge to MPV. Noncompliance by the other party to one or more of its obligations will release MPV of all its guarantee obligations. In the case of assembly of the other party's own products by Maretti, MPV will release itself from all guarantee stipulations. Moreover, our general delivery terms and conditions are applicable. These can be obtained from Maretti or can be downloaded from [www.maretti.com](http://www.maretti.com)

The installation must be done by a competent installer. Maretti recommends that your (outside) lighting and fixture annually to be inspect and maintain. For maintenance advice: [www.maretti.com/onderhoudsadvies.html](http://www.maretti.com/onderhoudsadvies.html)

D: Für garantiebedingungen bitte lesen sie unsere webseite [www.maretti.com/guaranteee.html](http://www.maretti.com/guaranteee.html)  
 E: Consulte nuestro sitio web para los condiciones de garantia [www.maretti.com/guaranteee.html](http://www.maretti.com/guaranteee.html)  
 FR: Consultez notre site web pour les conditions de garantie [www.maretti.com/guaranteee.html](http://www.maretti.com/guaranteee.html)  
 NL: Voor garantieverwaarden zie onze website [www.maretti.com/guaranteee.html](http://www.maretti.com/guaranteee.html)

13.1853.Colour | **STAGE CUBE FLOOR**

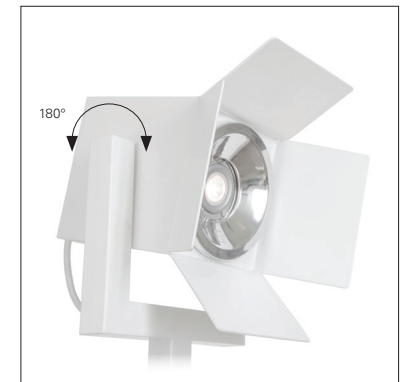
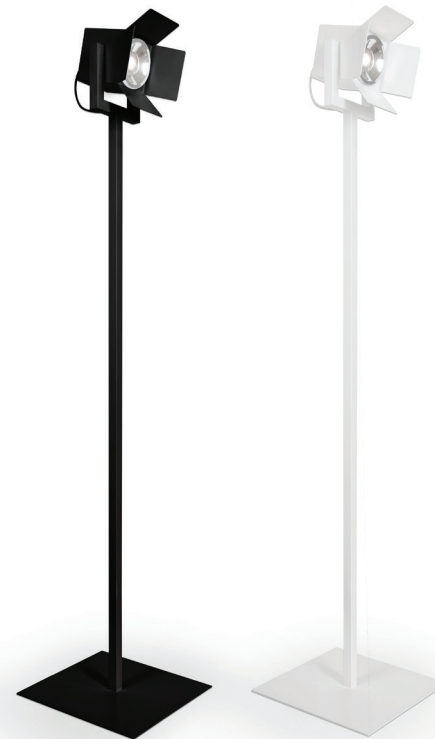

230V	VOLTAGE	IP	20	2700K	KELVIN		
35W	WATTAGE MAX.		INDOOR				
 GU10	LED BULB INCLUDED		CE MARK				
GU10	SOCKET	 180°	TWISTING				

ACCESSORIES  
SEPARATE ORDER

## BULB

Bulb (option)	Kelvin	Degree beam angle	Article number
 COLOMBIA LED GU10 5W RA82 380 lm dimmable	2800K	38°	<b>21.8270.07</b>

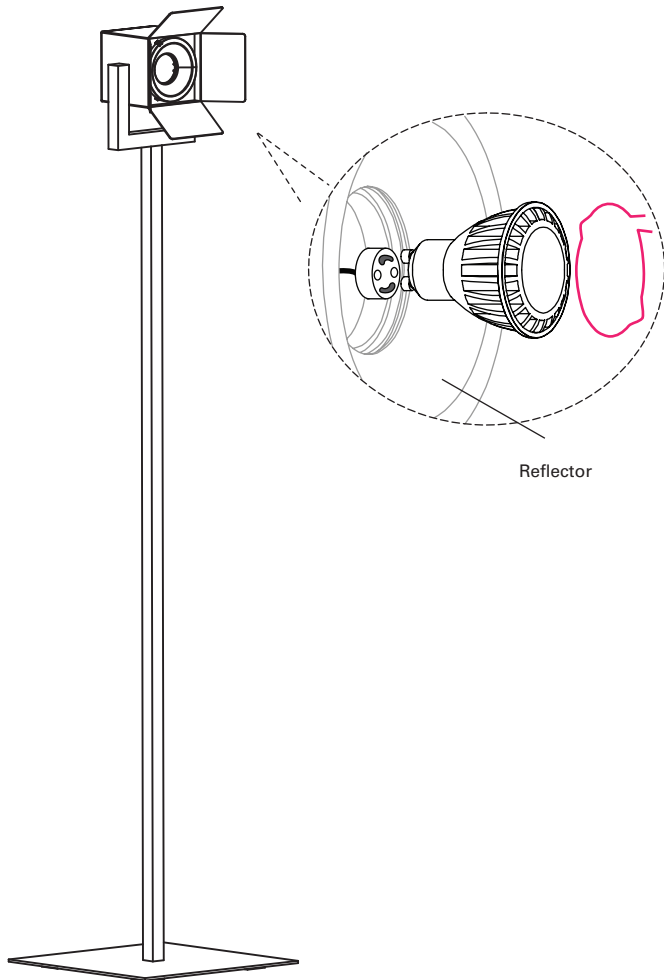

After installing the reflector on the fixture, place the light source on the lampholder and then put the ring like in the example

